

Jan. 7, 1969

G. G. HIRS

3,420,583

BEARING FOR RADIAL AND AXIAL LOADS

Filed May 17, 1966

FIG. 1

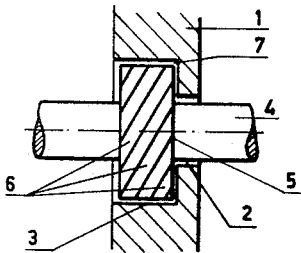

FIG. 2

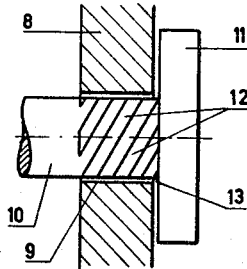

FIG. 3

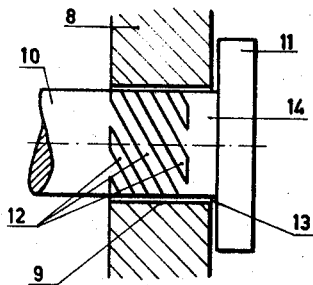
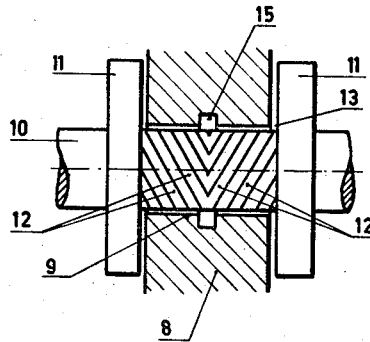

FIG. 4



INVENTOR.  
GILLES GERARDUS HIRS  
BY *Hammond and Fittell*  
ATTORNEYS

1

2

3,420,583

**BEARING FOR RADIAL AND AXIAL LOADS**  
 Gilles Gerardus Hirs, Reeuwijk, Netherlands, assignor to  
 Nederlandse Organisatie voor Toegepast-Natuurweten-  
 schappelijk Onderzoek ten behoeve van Nijverheid,  
 Handel en Verkeer, The Hague, Netherlands, a corpo- 5  
 ration of the Netherlands

Filed May 17, 1966, Ser. No. 550,741  
 Claims priority, application Netherlands, May 21, 1965,  
 6506475

U.S. Cl. 308-9  
 Int. Cl. F16c 35/00

2 Claims 10

**ABSTRACT OF THE DISCLOSURE**

A bearing for transmitting radial and axial loads be-  
 tween two elements which are rotatable with respect to  
 each other and each of which possesses a bearing surface  
 having a mainly cylindrical part and an adjoining mainly  
 flat radial part, the said elements, when operated nor-  
 mally, being separated by a slit-shaped space which is  
 filled with a medium that transmits the load. In depen-  
 dency on the application of the bearing, the medium  
 can be either a liquid or a gas.

These commonly used bearings give rise to a number  
 of problems. It is difficult to realize a proper hydro-or  
 aerodynamic lubrication for the flat part receiving the  
 axial load, unless expensive measures are taken. At the  
 same time, the stability of the known bearings is in-  
 sufficient for many applications, especially at high speeds  
 of revolution. The stability of the bearing is here under-  
 stood to mean the stability of the equilibrium between  
 the pressure distribution in the medium and the exterior  
 forces on the bearing. One may distinguish between the  
 stability of the cylindrical part and that of the flat part  
 of the bearing, which often have to meet different re-  
 quirements.

It is the object of this invention to provide an improve-  
 ment on the existing bearings in this respect.

For this purpose, the bearing according to the inven-  
 tion is characterized in that the slit-shaped space com-  
 prises at least two regions, one of the two bearing sur-  
 faces positioned opposite each other in the first region  
 being provided with a number of grooves, which are  
 placed in such a direction obliquely with respect to the  
 direction of motion that, at the direction of rotation, for  
 which the bearing is meant, they will cause a stemming of  
 the medium in the direction of the adjoining second re-  
 gion, and the slit-shaped space having approximately the  
 same width in and near the border of the two regions.

In the second region both the bearing surfaces may  
 be smooth, or one of the bearing surfaces may be pro-  
 vided with oblique grooves, which, at the normal direction  
 of rotation of the bearing, will cause a stemming of the  
 medium in the direction of the first region.

From the point of view of manufacturing technique  
 it may seem attractive to have the border between the  
 two regions coincide with the border between the cylin-  
 drical part of the bearing and the flat part of the bear-  
 ing. On the other hand, however, this gives rise to the  
 problem of constructing the border between these two  
 parts of the bearing in such a way that the rounded corner  
 of one part or the turned groove in the part opposite  
 shall not give rise to the formation of an annular channel  
 at this location. It is true that such a channel has no  
 unfavourable influence on the axial load carrying cap-  
 acity, because the stemming of the medium and the stab-  
 ilizing activity thereof on parallel axial displacements  
 remain maintained, but it causes a short-circuit at the  
 end of the grooves so that the annular channel would

otherwise bring about the complete loss of the stability  
 of the bearing.

Also, if an annular channel should be present in one  
 of the two regions, this would unfavourably influence  
 the stability, but not to the same degree. Generally speak-  
 ing, in such a case the stability of the bearing is de-  
 termined by that part of the bearing that comprises the  
 region without the channel and the other region as far  
 as to the channel.

It is possible to construct the bearing with more than  
 two regions, for instance with three regions, the bearing  
 surfaces in the middle region being smooth, and the other  
 two each having a bearing surface which is grooved in  
 such a way as to cause a stemming of the medium towards  
 the middle region. If in such a bearing an annular chan-  
 nel is present between two regions, the stability of the  
 bearing is determined by the two regions which are not  
 separated by this channel.

It is to be observed that the profile of the grooves is  
 not very critical. Preferably, a depth is chosen for the  
 grooves not larger than a few times the average width  
 of the slit, whilst the length of the grooves should be at  
 least a few times as large as the pitch of the grooves.

The invention will be further explained hereinafter  
 with reference to the accompanying drawing, in which  
 are shown cross-sections of a number of embodiments of  
 bearings according to this invention.

In the embodiment according to FIG. 1 the bore 2  
 and the larger bore 3 are provided in the bearing-case 1.  
 The thickened part 5 of the shaft 4 is positioned coaxially  
 in the bores 2 and 3, there being an ample clearance  
 between the shaft 4 and the bore 2 and a narrow slit  
 being present between the part 5 of the shaft 4 and the  
 bore 3.

The side surface of the thickened part 5 which is di-  
 rected toward the bore 2, and the surface of the bearing-  
 case 1 situated opposite it, are flat surfaces perpendicular  
 to the centre line of the shaft 4 and they constitute the  
 bearing part for the reception of the axial loads. The  
 outer surface of the part 5 is provided with grooves 6  
 and together with the bore 3 it forms the bearing part  
 that receives the radial loads.

The part 5 and the bore 3 in the case 1 are made in  
 such a way that the slit-shaped space between these two  
 is not larger at 7 than it is elsewhere.

When a medium is present in the space between the  
 shaft 4 and the bearing case 1 as well as outside of it,  
 the medium in the radial part of the bearing is stemmed  
 to the right by the grooves 6 and there is built up a  
 pressure, which is transmitted into the axial part of the  
 bearing and can receive an axial load of the shaft 4.  
 In dependency on the magnitude of the load, the slit  
 between these flat surfaces will be larger or smaller and  
 the pressure of the medium will assume a corresponding  
 smaller or larger value.

An eccentric position of the shaft 4 in the bore 3 will  
 locally cause a narrowing of the slit between the shaft  
 part 5 and the bore 3, so that at that location there arises  
 an increase of the pressure, which tends to neutralize the  
 eccentricity.

An oblique position of the shaft 4 in the bore 3 will  
 locally cause a narrowing of the slit between the flat  
 surfaces of the shaft part 5 and the bore 3 and at that  
 location it will bring about an increase of the resistance  
 of flow of the medium and in consequence thereof cause  
 a higher pressure of the medium, which counteracts the  
 oblique position of the shaft 4.

In case there should be present a circular channel in  
 the slit-shaped space at 7, because, for instance, at that  
 location, owing to inaccuracies in the technical finish,  
 the form of the shaft should not entirely correspond  
 with the form of the bore 3, the said channel would

distribute the pressure of the medium evenly over the whole of the periphery of the slit of the bearing, so that, at deviating positions of the shaft 4 with respect to its position of equilibrium, no stabilizing forces would occur, except for parallel displacements in axial direction.

In FIG. 2 is shown a bearing, in which the shaft 10 with the flange 11 is provided in the bore 9 of the bearing-case 8. The shaft 10 is provided with helical grooves 12. Between the bore 9 and the shaft 10, as also between the flange 11 and the flat side surface of the bearing-case 8, there is a narrow slit, which is filled with a medium, which is also present outside of the slit.

The operation of this bearing corresponds entirely to that according to FIG. 1. The stemming effect of the grooves 12 provides the axial load carrying capacity of the bearing, whilst, when there is a precise conformity of the shaft 10 and the bearing-case 8 at the location 13, where the two parts of the bearing border on each other, the medium has a stabilizing pressure distribution in a radial and in an axial sense.

The bearing according to FIG. 3 has the same arrangement as the one according to FIG. 2, however with this difference that the grooved region of the shaft 10 extends only over a section of the radially carrying part of the bearing and that the remaining part of the shaft 10 is smooth.

If, when producing this bearing, care is taken that no widening of the slit occurs in the border 13 between the two parts of the bearing, the operation of this bearing is entirely comparable to that of the bearing according to FIG. 2. If, however, such a widening of the slit 13 is actually present, it is impossible that, between the flat surfaces of the flange 11 and the bearing case 8, which carry the thrust load, there should be formed any stabilizing pressure distribution in the medium as to an oblique positioning of the two surfaces relative to one another. However, an annular channel near 13 has no harmful influence of any importance on the stability of the radially carrying part of the bearing, because the high resistance of the narrow slit in the ungrooved region of this part of the bearing prevents the occurrence of short circuit of tangential pressure gradients.

In this type of bearing, there are no special requirements for the finish of the shaft 10 and the bearing-case 8 at the location 13, if the stability against obliqueness of the axial part of the bearing is abandoned. This renders the bearing attractive for those cases, in which the stability against the obliqueness of the shaft has already been secured in some other way, which is the case, for instance, when a shaft is supported in two places by bearings situated at a sufficient distance from one another.

Lastly, FIG. 4 shows a bearing, which actually is a doubling of the bearing according to FIG. 2 and which is adapted to receive axial loads in two directions. In order to ensure the medium supply necessary for building up the pressure, there has been provided the annular chan-

nel 15, which is connected to a medium supply in a manner not indicated in the drawing.

In the examples of bearings described hereinbefore the surfaces in the parts of the bearing receiving the thrust loads are of smooth finish. It is, however, also possible, to provide these surfaces entirely or on one of their annular parts with grooves, which should run spirally in such a direction that, at the normal direction of rotation of the shaft, they will have a stemming effect in the direction of the cylindrical part of the bearing, which in this case may have smooth running surfaces, or again a grooved or a partly smooth and partly grooved running surface.

I claim:

1. A hydrodynamic bearing adapted to support radial and axial loads comprising a first cylindrical member having an enlarged position defining a plane flat surface projecting at right angles to said first member, a second member having an aperture and a plane flat surface projecting at right angles to said aperture, said aperture receiving said first member to form an annular interface and said surfaces of said first and second members forming a normal interface, a medium supplied to said annular interface between said first and second members, and helical distributing means disposed along said cylindrical member for distributing said medium from said annular member interface to said normal interface, the space located at the border of the annular and normal interfaces being not larger than a slit shaped space between the cylindrical member and said aperture whereby an oblique portion of the cylindrical member during operation in the aperture will locally cause a narrowing of the slit between the normal interface and will bring about an increase of resistance to flow of the medium and cause a higher pressure of the medium which counteracts the oblique position of the cylindrical member to center same.

2. A bearing according to claim 1 wherein said helical distributing means is a helical groove disposed along the longitudinal circumference of said cylindrical member to distribute said medium to said annular and normal interfaces.

#### References Cited

##### UNITED STATES PATENTS

3,027,471	3/1962	Burgwin et al.	308—9
3,048,043	8/1962	Slater et al.	
3,146,036	8/1964	Bennatti	308—9

##### FOREIGN PATENTS

1,011,413 12/1965 Great Britain.

MARTIN P. SCHWADRON, *Primary Examiner.*

FRANK SUSKO, *Assistant Examiner.*